

### TRAC MASS-TER FLAT STORAGE UNLOADER

**SPECIFICATIONS:**

|                           |                              |
|---------------------------|------------------------------|
| CAPACITY:                 | 10,000 BPH (270 TPH)         |
| GATHERING FLIGHT:         | 16" (40.6 cm) O.D.           |
| CONVEYOR CHAIN:           | 81X HH                       |
| GRAIN CONVEYING SECTION:  | 7" x 13" (17.8 cm x 33.0 cm) |
| HOUSING BOTTOM:           | 10 Ga. (3.43 mm) Galvanized  |
| CONVEYOR SPROCKET:        | 16 Tooth                     |
| CHAIN SPEED:              | 397 Feet (120 m) per minute  |
| GATHERING CONVEYOR SPEED: | 114 RPM                      |
| TAKE UP LOCATION:         | Head                         |
| PADDLES:                  | 1/2" (13 mm) UHMW            |
| DISCHARGE OPENING:        | Rectangular                  |
| CONVEYOR LENGTH:          | 40' (12.19 m)                |

Each Trac Mass-ter is made with durable galvanized housing and includes hydraulic lift and tubular, welded undercarriage designed to fit a category #2 three point hitch. Adapter kit for category #3 three point hitch is optional.

The "gathering conveyor" and inclined conveyor run off one PTO drive which includes a PTO Driveline with slip clutch for overload protection. 15" (38.1 cm) six bolt rims are provided. Spout sold separately.



See page 2 for dimensional information.

| CATALOG NO.      | DESCRIPTION  | Weight                 | List Price             |
|------------------|--|------------------------|------------------------|
| MT9040<br>M85382 | 40' (12.19 m) Trac Mass-ter<br>* Head Adapter Spout, 14" (35.6 cm) Round Opening | 4200 lbs.<br>(1905 kg) | \$ 22,803.00<br>308.00 |
| MT9010           | ACCESSORIES<br>Intake Hopper   |                        | 454.00                 |
| MT9011           | Hydraulic Adjustable Spout   |                        | 1,003.00               |
| MT9013           | Hydraulic Swivel Spout   |                        | 2,355.00               |
| MT9015           | Adapter Kit for category #3 three point Hitch                                    |                        | 196.00                 |

\* NOTE: Head Adapter Spout is not required when using any of the optional hydraulic spouts.

A front tractor mount is included with the Trac Mass-ter. Field modification will likely be necessary to fit your tractor.

TIRES — Add "8" to Catalog No., i.e. MT90408. Add \$550.00 to List Price.

## TRAC MASS-TER FLAT STORAGE UNLOADER

| Model Length     | A                | B               | C                | D                  | E Max.             | F Min.          | F Max.          |
|------------------|------------------|-----------------|------------------|--------------------|--------------------|-----------------|-----------------|
| 40'<br>(12.19 m) | 40'<br>(12.19 m) | 12'<br>(3.66 m) | 35'<br>(10.67 m) | 11'-9"<br>(3.58 m) | 21'-6"<br>(6.55 m) | 15'<br>(4.57 m) | 24'<br>(7.32 m) |

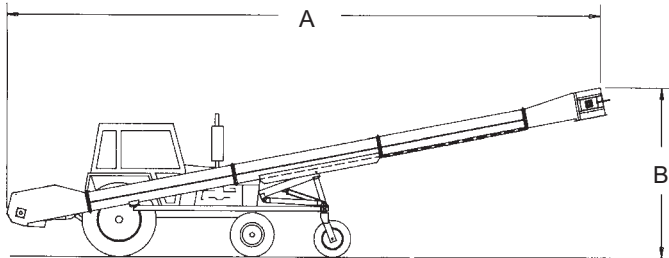

Side View in Transport Position

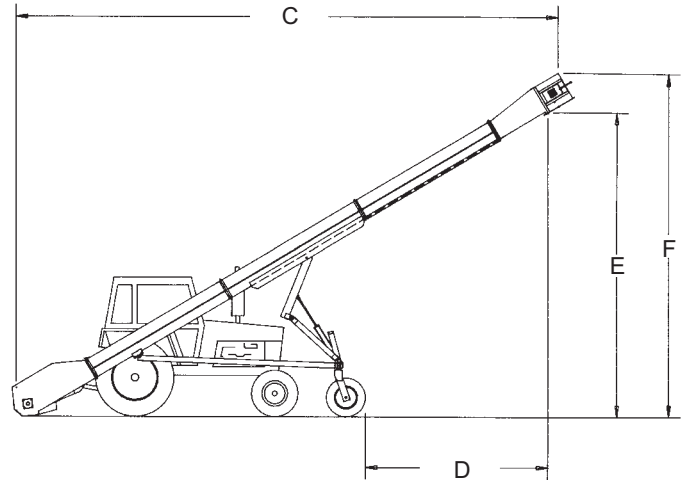

Side View in Loading Position

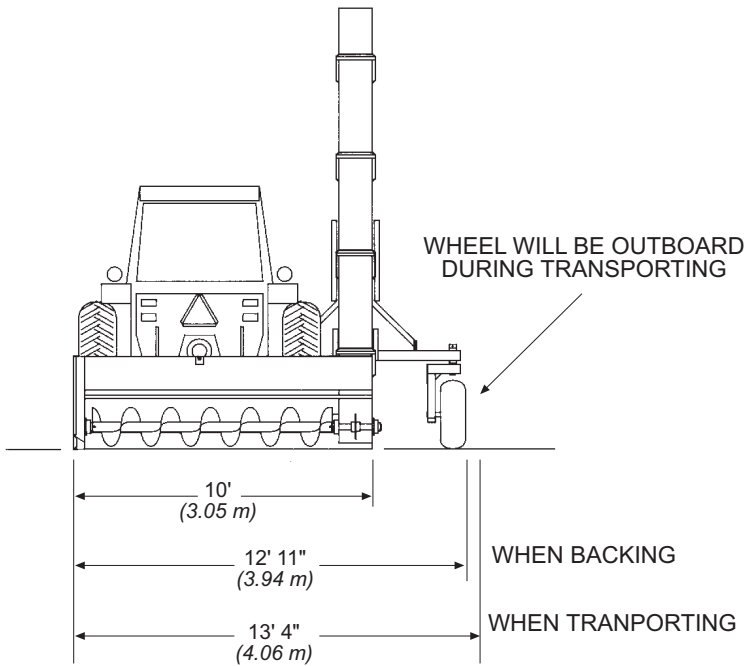

Back View

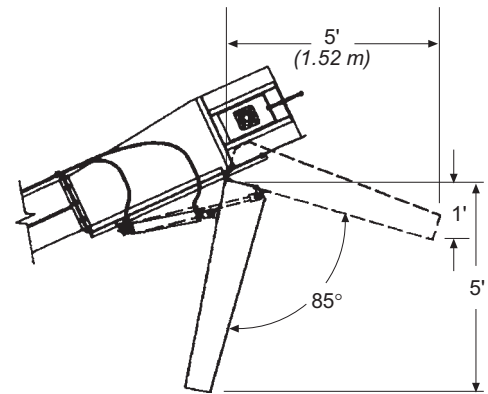

Optional Hydraulic Adjustable Spout (MT9011)

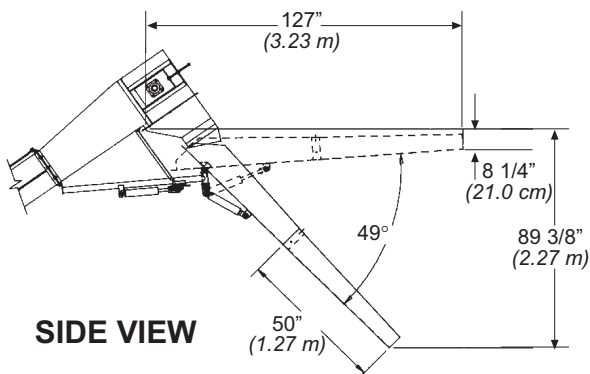

SIDE VIEW

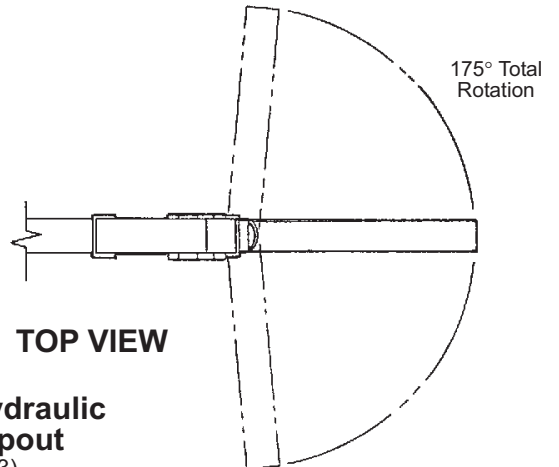

TOP VIEW

Optional Hydraulic Swivel Spout (MT9013)

## PORTABLE GRAIN PUMP & MASS-TER MOVER DIMENSIONAL INFORMATION

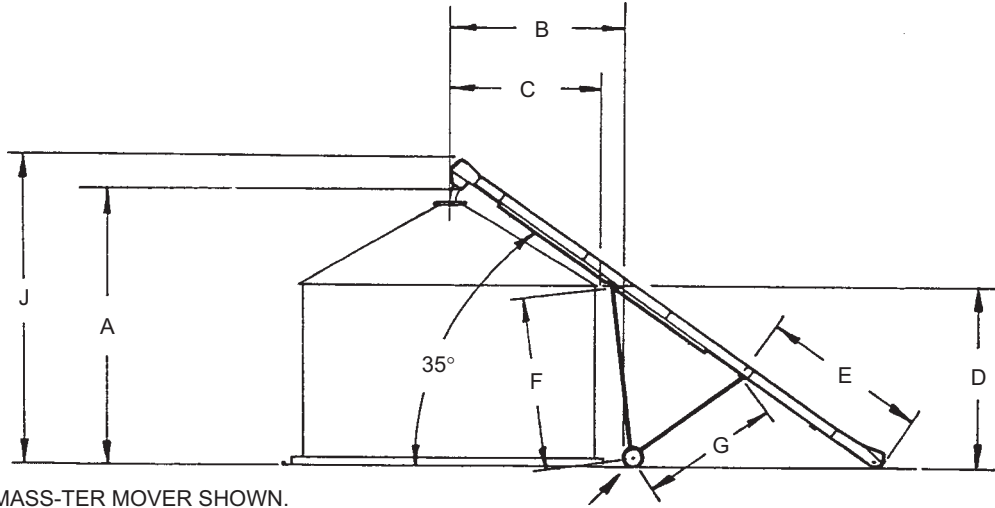

NOTE: MASS-TER MOVER SHOWN.

| 8" & 10" GRAIN PUMP |                            |                         |                            |                            |                            |                          |                          |
|---------------------|----------------------------|-------------------------|----------------------------|----------------------------|----------------------------|--------------------------|--------------------------|
| MODEL               | OVERALL TRANSPORT HEIGHT** | OVERALL TRANSPORT WIDTH | DISCHARGE HEIGHT @ 30 DEG. | DISCHARGE HEIGHT @ 35 DEG. | CLEARANCE HEIGHT @ 35 DEG. | REACH DISTANCE @ 35 DEG. | DISCHARGE HEIGHT MAXIMUM |
|                     |                            |                         | (A)                        | (A)                        | (B)                        | (C)                      | (A)                      |
| 8" x 42'            | 10'-8"                     | 9'-6"                   | 19'-3"                     | 22'-3"                     | 13'-9"                     | 14'-0"                   | 24'-2"                   |
| (20.3 cm x 12.80 m) | (3.25 m)                   | (2.90 m)                | (5.87 m)                   | (6.78 m)                   | (4.19 m)                   | (4.27 m)                 | (7.37 m)                 |
| 8" x 52'            | 11'-3"                     | 9'-6"                   | 24'-3"                     | 28'-0"                     | 17'-0"                     | 17'-9"                   | 31'-7"                   |
| (20.3 cm x 15.85 m) | (3.43 m)                   | (2.90 m)                | (7.39 m)                   | (8.53 m)                   | (5.18 m)                   | (5.41 m)                 | (9.63 m)                 |
| 8" x 62'            | 13'-4"                     | 10'-10"                 | 29'-3"                     | 33'-9"                     | 20'-1"                     | 21'-6"                   | 38'-0"                   |
| (20.3 cm x 15.85 m) | (4.06 m)                   | (3.30 m)                | (8.92 m)                   | (10.29 m)                  | (6.12 m)                   | (6.55 m)                 | (11.58 m)                |
| 8" x 72'            | 15'-1"                     | 12'-10"                 | 34'-3"                     | 39'-6"                     | 22'-6"                     | 26'-4"                   | 44'-3"                   |
| (20.3 cm x 21.95 m) | (4.60 m)                   | (3.91 m)                | (10.44 m)                  | (12.04 m)                  | (6.86 m)                   | (8.03 m)                 | (13.49 m)                |
| 10" x 72'           | 14'-6"                     | 12'-10"                 | 34'-10"                    | 40'-2"                     | 21'-9"                     | 28'-9"                   | 45'-8"                   |
| (25.4 cm x 21.95 m) | (4.42 m)                   | (3.91 m)                | (10.62 m)                  | (12.24 m)                  | (6.63 m)                   | (8.76 m)                 | (13.92 m)                |
| 10" x 82'           | 16'-3"                     | 12'-10"                 | 40'-0"                     | 45'-11"                    | 26'-1"                     | 30'-9"                   | 51'-2"                   |
| (25.4 cm x 24.99 m) | (4.95 m)                   | (3.91 m)                | (12.19 m)                  | (14.00 m)                  | (7.95 m)                   | (9.37 m)                 | (15.60 m)                |

\*\* Overall Transport Height is with intake on the ground. Actual height will be lower when attached to towing vehicle.

| MODEL 50 MASS-TER MOVER BOTTOM DRIVE |           |           |           |           |          |            |            |             |          |          |
|--------------------------------------|-----------|-----------|-----------|-----------|----------|------------|------------|-------------|----------|----------|
|                                      | A1        | A2        | B         | C         | D        | E          | F          | G           | H        | J        |
| 40'                                  | 27'-0"    | 22'-4"    | 13'-0"    | 12'-0"    | 14'-2"   | 12'-8"     | 12'-8"     | 10'-2"      | 8'-2"    | 12'-6"   |
| (12.19 m)                            | (8.23 m)  | (6.81 m)  | (3.96 m)  | (3.66 m)  | (4.23 m) | (3.86 m)   | (3.86 m)   | (3.10 m)    | (2.49 m) | (3.81 m) |
| 50'                                  | 34'-0"    | 27'-1"    | 16'-5"    | 15'-1"    | 17'-8"   | 15'-11"    | 16'-7"     | 13'-1"      | 8'-9"    | 14'-7"   |
| (15.24 m)                            | (10.36 m) | (8.26 m)  | (5.00 m)  | (4.60 m)  | (5.38 m) | (4.85 m)   | (5.05 m)   | (3.99 m)    | (2.67 m) | (4.45 m) |
| 60'                                  | 40'-7"    | 32'-6"    | 22'-10"   | 22'-2"    | 18'-0"   | 16'-6 1/2" | 17'-0"     | 14'-2"      | 8'-9"    | 15'-0"   |
| (18.29 m)                            | (12.37 m) | (9.91 m)  | (6.96 m)  | (6.76 m)  | (5.49 m) | (5.04 m)   | (5.18 m)   | (4.32 m)    | (2.67 m) | (4.57 m) |
| 65'                                  | 44'-1"    | 35'-4"    | 23'-9"    | 22'-10"   | 20'-11"  | 16'-6 1/2" | 20'-0"     | 17'-0"      | 8'-9"    | 16'-0"   |
| (19.81 m)                            | (13.44 m) | (10.77 m) | (7.24 m)  | (6.96 m)  | (6.38 m) | (5.04 m)   | (6.10 m)   | (5.18 m)    | (2.67 m) | (4.88 m) |
| 70'                                  | 43'-1"    | 38'-3"    | 28'-4"    | 26'-6"    | 21'-3"   | 18'-5"     | 20'-3 1/2" | 16'-0"      | 10'-11"  | 15'-2"   |
| (21.34 m)                            | (13.13 m) | (11.66 m) | (8.64 m)  | (8.08 m)  | (6.48 m) | (5.61 m)   | (6.18 m)   | (4.88 m)    | (3.33 m) | (4.62 m) |
| 80'                                  | 49'-6"    | 43'-11"   | 32'-5"    | 31'-6"    | 23'-4"   | 20'-6 1/2" | 22'-5"     | 18'-8 1/2"  | 11'-11"  | 17'-2"   |
| (24.38 m)                            | (15.09 m) | (13.39 m) | (9.88 m)  | (9.60 m)  | (7.11 m) | (6.26 m)   | (6.83 m)   | (5.70 m)    | (3.63 m) | (5.23 m) |
| 90'                                  | 55'-11"   | 49'-8"    | 35'-3"    | 34'-9"    | 26'-6"   | 22'-3 1/2" | 24'-8"     | 21'-11 1/4" | 14'-3"   | 17'-6"   |
| (27.43 m)                            | (17.04 m) | (15.14 m) | (10.74 m) | (10.59 m) | (8.08 m) | (6.79 m)   | (7.52 m)   | (6.69 m)    | (4.34 m) | (5.33 m) |
| 100'                                 | 62'-4"    | 55'-5"    | 41'-10"   | 42'-4"    | 27'-6"   | 26'-10"    | 26'-4"     | 22'-5"      | 14'-3"   | 21'-1"   |
| (30.48 m)                            | (19.00 m) | (16.89 m) | (12.75 m) | (12.90 m) | (8.38 m) | (8.18 m)   | (8.03 m)   | (6.83 m)    | (4.34 m) | (6.43 m) |

- |    |  |    |                                      |
|----|--|----|--------------------------------------|
| A1 | Maximum Discharge Height (Approx. 45°)     | E  | Intake to lower arm attachment       |
| A2 | Discharge height at 35°                    | F  | Upper Undercarriage Arm Length       |
| B  | Closest point to bin at 35° (Ground level) | G  | Lower Undercarriage Arm Length       |
| C  | Closest point to bin at 35° (Eave level)   | H  | Tread Width center of Tire           |
| D  | Free Clearance Above Wheels                | J* | Overall Height in Transport Position |

\* Transport height will be lower when attached to drawbar of towing vehicle.

### 8" GRAIN PUMP

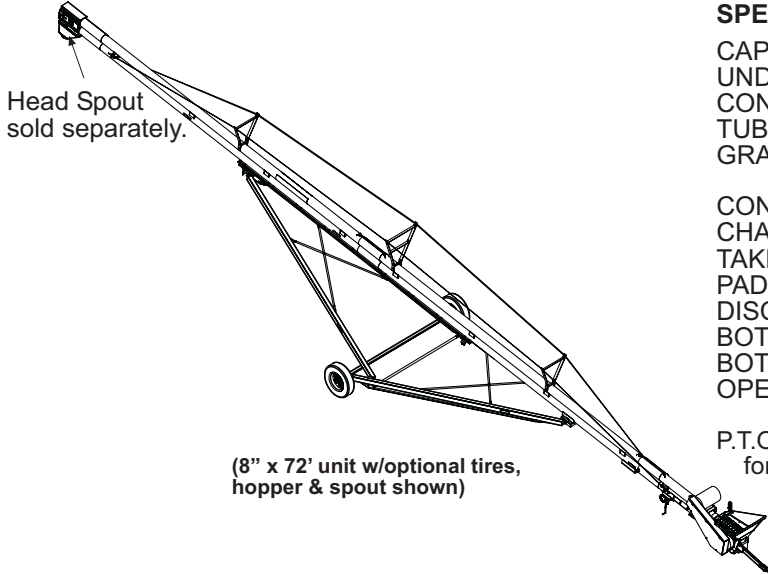

(8" x 72' unit w/optional tires, hopper & spout shown)

#### SPECIFICATIONS:

|                     |  |
|---------------------|--|
| CAPACITY:           | 4,000 BPH (108 TPH)  |
| UNDERCARRIAGE:      | High Strength Tubing   |
| CONVEYOR CHAIN:     | 81X  |
| TUBE HOUSING:       | 8" (20.3 cm) Diameter  |
| GRAIN PUMP LENGTHS: | 42', 52', 62' & 72'<br>(12.80 m, 15.85 m, 18.90 m & 21.95 m) |
| CONVEYOR SPROCKETS: | 12 Tooth   |
| CHAIN SPEED:        | 315 feet (96.01 m) per minute                                |
| TAKE UP LOCATION:   | Head   |
| PADDLES:            | 3/8" (10 mm) UHMW  |
| DISCHARGE OPENING:  | 10" (25.4 cm) Round  |
| BOTTOM DRIVE:       | Gear Reducer   |
| BOTTOM DRIVE:       | Electric or Direct P.T.O.                                    |
| OPERATIONAL RANGE:  | Up to 40°  |

P.T.O. Driveline includes shear device for overload protection. 540 RPM.

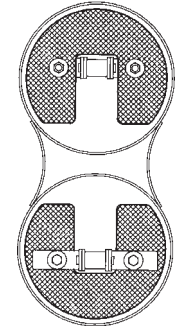

CROSS SECTION OF HOUSING

#### INCLUDES:

- 14 GA. (1.9 mm) GALVANIZED HOUSING
- UNDERCARRIAGE
- HITCH
- REDUCTION WINCH
- TAPERED ROLLER WHEEL BEARINGS
- 15" RIMS (38.1 cm) (LESS TIRES) ON 42' & 52'
- 16" RIMS (40.6 cm) (LESS TIRES) ON 62' & 72'

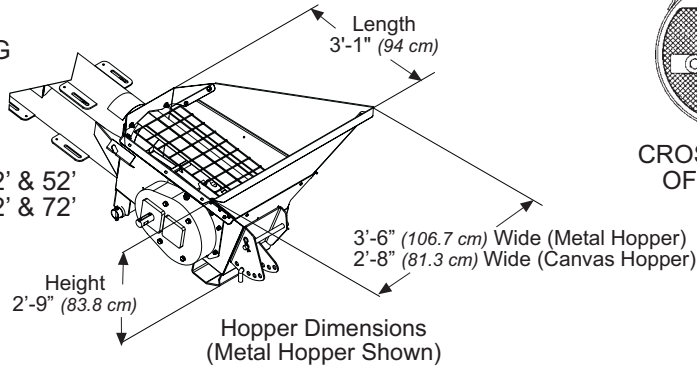

| CATALOG NO. | Description                        | Req'd Power   | Weight              | List Price  |
|-------------|------------------------------------|---------------|---------------------|-------------|
| P084201EB   | 8" x 42' Electric Drive Grain Pump | 10 HP (11 kw) | 2100 lbs. (953 kg)  | \$13,097.00 |
| P084201PB   | 8" x 42' PTO Drive Grain Pump      | --            | 2100 lbs. (953 kg)  | 13,216.00   |
| P085201EB   | 8" x 52' Electric Drive Grain Pump | 15 HP (11 kw) | 2500 lbs. (1134 kg) | 12,984.00   |
| P085201PB   | 8" x 52' PTO Drive Grain Pump      | --            | 2500 lbs. (1134 kg) | 13,023.00   |
| P086201EB   | 8" x 62' Electric Drive Grain Pump | 15 HP (11 kw) | 3250 lbs. (1474 kg) | 14,373.00   |
| P086201PB   | 8" x 62' PTO Drive Grain Pump      | --            | 3250 lbs. (1474 kg) | 14,405.00   |
| P087201EB   | 8" x 72' Electric Drive Grain Pump | 15 HP (11 kw) | 3650 lbs. (1656 kg) | 15,371.00   |
| P087201PB   | 8" x 72' PTO Drive Grain Pump      | --            | 3650 lbs. (1656 kg) | 15,412.00   |
| P0804A      | Spring Supported Canvas Hopper     | --            | 33 lbs. (15 kg)     | 399.00      |
| P0805A      | Metal Hopper                       | --            | 31 lbs. (14 kg)     | 133.00      |
| P0806A      | Cover f/Metal Hopper               | --            | 42 lbs. (19 kg)     | 120.00      |
| P0807BP     | PTO Drive Conversion               | --            | 79 lbs. (36 kg)     | 758.00      |
| P0808BE     | Electric Drive Conversion          | --            | 144 lbs. (65 kg)    | 713.00      |
| *P2867A     | 8" 90° Head Spout                  | --            | 30 lbs. (14 kg)     | 171.00      |
| *P2868A     | 8" 45° Head Spout                  | --            | 33 lbs. (15 kg)     | 245.00      |

\* Standard with 10" (25.4 cm) outlet.

110 Volt ELECTRIC or HYDRAULIC Winch

ELECTRIC WINCH - Add "3" to Catalog No., i.e. P086201EB3. Add \$1,850.00 to List Price. (Not available for 42' Model.)

HYDRAULIC WINCH - Add "4" to Catalog No., i.e. P086201EB4. Add \$1,475.00 to List Price. (Not available for 42' Model.)

| TIRES - | Add | Model     | Tire                                     | Example     | Add to List |
|---------|-----|-----------|--|-------------|-------------|
|         | 8   | 42' & 52' | Standard Implement                       | P085201EB8  | \$170.00    |
|         | 8   | 62', 72'  | 235/85R16 - 10 PLY Tire w/6" wide wheels | P086201EB8  | \$550.00    |
|         | 88  | 42' & 52' | Automotive Tire                          | P085201EB88 | \$273.00    |

### 10" GRAIN PUMP

#### SPECIFICATIONS:

CAPACITY: 6,000 BPH (162 TPH)  
 UNDERCARRIAGE: High Strength Tubing  
 CONVEYOR CHAIN: 81XHH  
 TUBE HOUSING: 10" (25.4 cm) Diameter  
 GRAIN PUMP LENGTHS: 72' & 82' (21.95 m & 24.99 m)  
 CHAIN SPEED: 349 feet (106.38 m) per minute  
 TAKE UP LOCATION: Head  
 PADDLES: 1/2" (13 mm) UHMW  
 BOTTOM DRIVE: Gear Reduction  
 OPERATIONAL RANGE: Up to 40°  
 LIFT SYSTEM: Hydraulic Winch

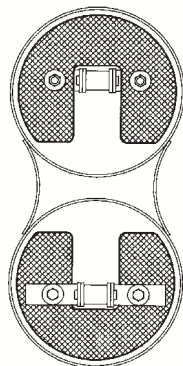
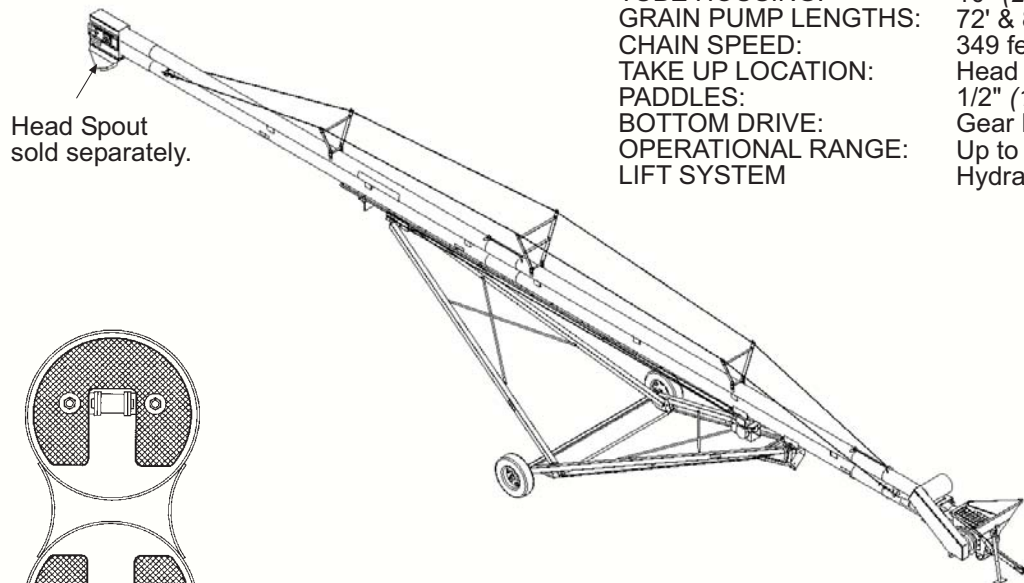

CROSS SECTION OF HOUSING

#### INCLUDES:

12 GA. (2.66 mm) GALVANIZED HOUSING  
 UNDERCARRIAGE  
 HITCH WITH JACK  
 HYDRAULIC WINCH  
 TAPERED ROLLER WHEEL BEARINGS  
 16" (40.6 cm) RIMS (LESS TIRES)  
 INLET HOPPER  
 GEAR REDUCTION DRIVE  
 PTO DRIVE MODEL -- 540 RPM

| CATALOG NO. | Description   | Req'd Power     | Weight              | List Price  |
|-------------|---|-----------------|---------------------|-------------|
| P107202EB   | 10" x 72' (25.4 cm x 21.95 m) Electric Drive Grain Pump | 25 HP (18.5 kw) | 4900 lbs. (2223 kg) | \$26,431.00 |
| P107202PB   | 10" x 72' (25.4 cm x 21.95 m) PTO Drive Grain Pump      | --              | 4900 lbs. (2223 kg) | 26,257.00   |
| P108202EB   | 10" x 82' (25.4 cm x 24.99 m) Electric Drive Grain Pump | 25 HP (18.5 kw) | 5500 lbs. (2495 kg) | 28,446.00   |
| P108202PB   | 10" x 82' (25.4 cm x 24.99 m) PTO Drive Grain Pump      | --              | 5500 lbs. (2495 kg) | 28,275.00   |
| P3067A      | Head Discharge Spout 90°                                | --              | 31 lbs. (14 kg)     | 177.00      |
| P3066A      | Head Discharge Spout 60°                                | --              | 38 lbs. (17 kg)     | 189.00      |
| P3068A      | Head Discharge Spout 45°                                | --              | 42 lbs. (19 kg)     | 189.00      |
| P3073A      | Hopper Cover  | --              | 48 lbs. (22 kg)     | 142.00      |

Electric Winch (5 HP, 220V, 3-phase) - Add "3" to Catalog No., i.e. P107202EB3. Add \$660.00 to List Price.

| TIRES - | Add | Tire                 | Example    | Add to List |
|---------|-----|----------------------|------------|-------------|
|         | 8   | Heavy Duty Implement | P107202EB8 | \$550.00    |

### MODEL 50 MASS-TER MOVER with BOTTOM DRIVE

**INCLUDES:**

- GALVANIZED HOUSING
- UNDERCARRIAGE
- 90° SPOUT - 10" (25.4 cm) OUTLET
- HITCH & JACK
- HYDRAULIC OR MANUAL WINCH
- TAPERED ROLLER WHEEL BEARINGS
- 15" (38.1 cm) RIMS (LESS TIRES) ON 40'
- 16" (40.6 cm) RIMS (LESS TIRES) ON 50'-100'
- GEAR REDUCER DRIVE

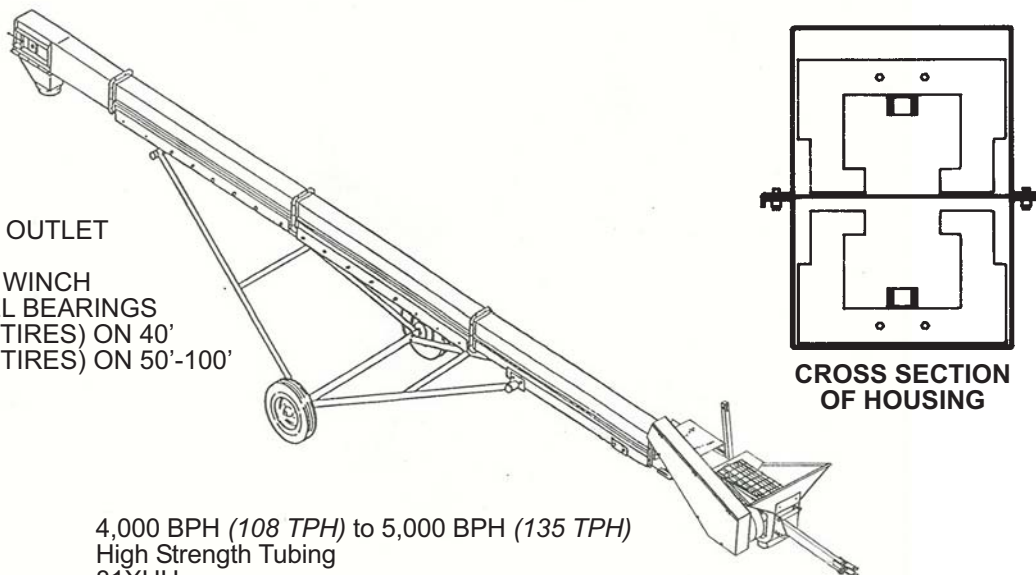

**SPECIFICATIONS:**

- CAPACITY: 4,000 BPH (108 TPH) to 5,000 BPH (135 TPH)
- UNDERCARRIAGE: High Strength Tubing
- CONVEYOR CHAIN: 81XHH
- GRAIN CONVEYING SECTION: 6" x 9" (15.2 cm x 22.9 cm)
- HOUSING BOTTOM: 10 ga. (3.43 mm) Galvanized
- MASS-TER MOVER LENGTHS: 40', 50', 60', 65', 70', 80', 90', & 100'
- CHAIN SPEED: 310 feet (94.49 m) per minute
- TAKE UP LOCATION: Head
- PADDLES: 3/8" (10 mm) UHMW
- DISCHARGE OPENING: 10" (25.4 cm) Round
- DRIVE: Electric or P.T.O.
- OPERATIONAL RANGE: Up to 40°
- MANUAL WINCH: 40'-65' (12.19 m - 19.81 m) Models
- HYDRAULIC WINCH: 70'-100' (21.34 m - 30.48 m) Models

P.T.O. Drive is 540 RPM and drives directly to the gear reducer at the boot shaft.

| Length          | Weight              | Electric Drive (less motor) |                 |              | PTO Drive (with PTO Shaft) |             |
|-----------------|---------------------|-----------------------------|-----------------|--------------|----------------------------|-------------|
|                 |                     | Order No.                   | Req'd. Power    | List Price   | Order No.                  | List Price  |
| 40' (12.19 m)   | 2250 lbs. (1021 kg) | M500402EB                   | 15 HP (11 kw)   | \$ 15,695.00 | M500402PB                  | \$15,624.00 |
| 50' (15.24 m)   | 2750 lbs. (1247 kg) | M500502EB                   | 15 HP (11 kw)   | 17,365.00    | M500502PB                  | 17,296.00   |
| 60' (18.29 m)   | 3225 lbs. (1463 kg) | M500602EB                   | 20 HP (15 kw)   | 19,347.00    | M500602PB                  | 19,279.00   |
| 65' (19.81 m)   | 3450 lbs. (1565 kg) | M500652EB                   | 20 HP (15 kw)   | 20,463.00    | M500652PB                  | 20,395.00   |
| * 70' (21.34 m) | 4400 lbs. (1996 kg) | M500702EB                   | 20 HP (15 kw)   | 24,603.00    | M500702PB                  | 24,537.00   |
| * 80' (24.38 m) | 4850 lbs. (2200 kg) | M500802EB                   | 25 HP (18.5 kw) | 28,391.00    | M500802PB                  | 28,211.00   |
| * 90' (27.43 m) | 5325 lbs. (2415 kg) | M500902EB                   | 25 HP (18.5 kw) | 30,312.00    | M500902PB                  | 30,131.00   |
| *100' (30.48 m) | 5850 lbs. (2654 kg) | M501002EB                   | 25 HP (18.5 kw) | 32,266.00    | M501002PB                  | 32,093.00   |

HYDRAULIC WINCH - Add "4" to Catalog No., i.e. M500652EB4. Add \$1,475.00 to List Price.

110 VOLT ELECTRIC WINCH - Add "3" to Catalog No., i.e. M500652EB3. Add \$1,850.00 to List Price.

Available on lengths 40 ft. (12.19 m) to 65 ft. (19.81 m)

90° Spout with 12" Outlet instead of 10" Outlet - Add "12" to Catalog No., i.e. M50652EH-12, No Charge.

| TIRES - | Add | Model      | Tire                  | Example     | Add to List |
|---------|-----|------------|-----------------------|-------------|-------------|
|         | 8   | 40'        | Standard Implement    | M500402PB8  | \$170.00    |
|         | 8   | 50' - 100' | 235/85R16 10 PLY Tire | M500652PB8  | \$550.00    |
|         | 88  | 40'        | Automotive Tire       | M500402PB88 | \$273.00    |

\* Standard with Hydraulic Winch.

### MODEL 85 MASS-TER MOVER with BOTTOM DRIVE

**INCLUDES:**

- GALVANIZED HOUSING
- UNDERCARRIAGE
- 70° SPOUT - 14" (35.6 cm) OUTLET
- HITCH & JACK
- HYDRAULIC OR MANUAL WINCH
- INLET HOPPER
- 15" (38.1 cm) RIMS (LESS TIRES) ON 40'
- 16" (40.6 cm) RIMS (LESS TIRES) ON 65' & 70'
- 16" (40.6 cm) or 16.1" (40.9 cm) RIMS ON 80' & 90'
- GEAR REDUCER DRIVE

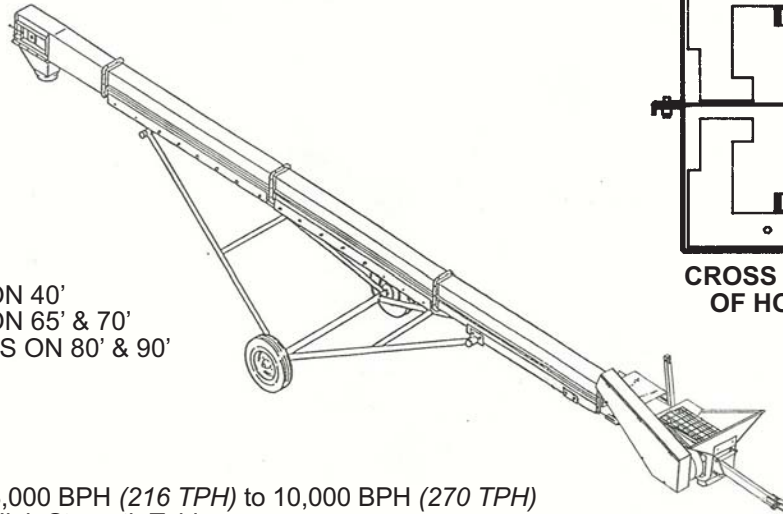

**CROSS SECTION  
OF HOUSING**

**SPECIFICATIONS:**

- CAPACITY: 8,000 BPH (216 TPH) to 10,000 BPH (270 TPH)
- UNDERCARRIAGE: High Strength Tubing
- CONVEYOR CHAIN: 81XHH
- GRAIN CONVEYING SECTION: 7" x 13" (17.8 cm x 33.0 cm)
- HOUSING BOTTOM: 10 ga. (3.43 mm) Galvanized
- MASS-TER MOVER LENGTHS: 40', 65', 70', 80' & 90'
- CHAIN SPEED: 400 feet (122 m) per minute
- TAKE UP LOCATION: Head
- PADDLES: 1/2" (13 mm) UHMW
- DISCHARGE OPENING: 14" (35.6 cm) Round
- DRIVE: Electric or P.T.O.
- OPERATIONAL RANGE: Up to 40°
- MANUAL WINCH: 40' (12.19 m) Models
- HYDRAULIC WINCH: 65'-90' (19.81 m - 27.43 m) Models
- PTO DRIVE: 540 RPM with Jack Shaft and "V" Belt Drive
- ELECTRIC DRIVE: Motor Mount, Guard and "V" Belt Drive

| Length        | Weight              | Electric Drive<br>(less motor) |               |              | PTO Drive<br>(with PTO Shaft) |             |
|---------------|---------------------|--------------------------------|---------------|--------------|-------------------------------|-------------|
|               |                     | Order No.                      | Req'd. Power  | List Price   | Order No.                     | List Price  |
| 40' (12.19 m) | 3700 lbs. (1678 kg) | M850402EB                      | 20 HP (15 kw) | \$ 18,428.00 | M850402PB                     | \$19,732.00 |
| 65' (19.81 m) | 5800 lbs. (2631 kg) | M850652EB                      | 30 HP (22 kw) | 29,699.00    | M850652PB                     | 30,248.00   |
| 70' (21.34 m) | 6300 lbs. (2858 kg) | M850702EB                      | 40 HP (30 kw) | 31,739.00    | M850702PB                     | 33,264.00   |
| 80' (24.38 m) | 7900 lbs. (3583 kg) | *M850802EB8                    | 40 HP (30 kw) | 38,482.00    | *M850802PB8                   | 40,048.00   |
| 90' (27.43 m) | 9000 lbs. (4082 kg) | *M850902EB8                    | 50 HP (37 kw) | 41,054.00    | *M850902PB8                   | 42,585.00   |

\* 80' & 90' lengths come standard with used aircraft tires mounted on 16" diameter x 10" wide rims.

Electric Winch (5 HP, 220 V, 3-phase) - Add "3" to Catalog No., i.e. M850652EB3. Add \$660.00 to List Price.  
Not available for 40'.

Inlet Hopper Extension - M8503A - \$221.00.

Hopper Cover - M8504A - \$115.00.

| TIRES - | Add | Model     | Tire   | Example     | Add to List |
|---------|-----|-----------|--|-------------|-------------|
|         | 8   | 40'       | Standard Implement                             | M850402PB8  | \$ 170.00   |
|         | 8   | 65' - 70' | 235/85R16 10 PLY Tire                          | M850702PB8  | \$ 550.00   |
|         | 8   | 80' & 90' | New 16.5 x 16.1 10 PLY Tire on 16.1" x 14" Rim | M850802PB88 | \$1,335.00  |

